

MICTOR SB .8mm (Samtec QSE/QTE) 120 contact Splitter Assembly

POLICY
 Splitter assemblies are considered "custom," non-returnable items. Tyco Electronics does not take responsibility for any errors in configuration based on customer specifications entered on this form.

NOTE: Splitter assemblies are those with a single connector on End 1 and multiple connectors on End 2.

Step 1: Using the table below, choose the End 2 Connector Scheme and enter letter

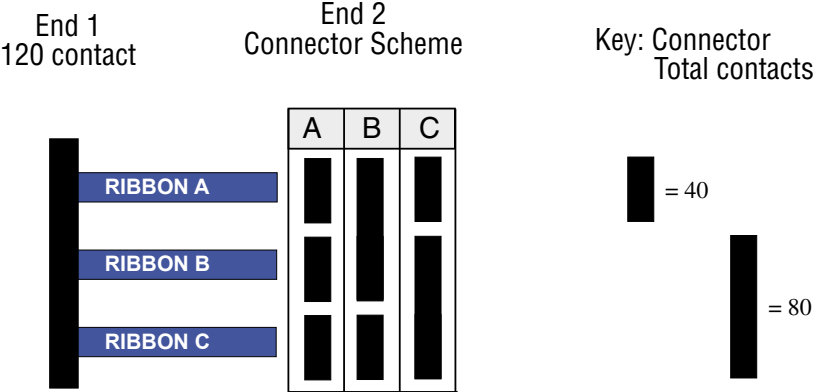

Step 2: Enter the length for each coax ribbon:

Ribbon A cm

Ribbon B cm

Ribbon C cm

NOTE: Each End 2 connector can have a different ribbon length. However, all ribbons going to a single connector must be the same. For example using connector scheme C

	<u>VALID</u>	<u>IN VALID</u>
Ribbon A	10cm	10cm
Ribbon B	20cm	20cm
Ribbon C	20cm	30cm

NOTE: The overall length for each connector will be approximately 2-3 cm longer due to added length of conductors and housing.

MICTOR SB .8mm (Samtec QSE/QTE) 120 contact Splitter Assembly

Step 3: For End 1, enter the orientation of the 120 contact connector based on the table below:

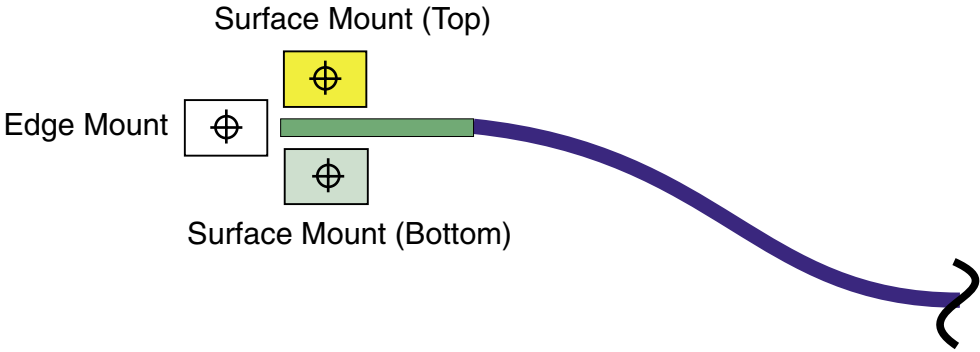

A	B	C	D
E	F	G	H
J	K	N	P

KEY

Plug Symbol

Receptacle Symbol

Note: small rectangle shows chamfer side (OPPOSITE row containing Pin 1)

MICTOR SB .8mm (Samtec QSE/QTE) 120 contact Splitter Assembly

Step 4: Using a column in the table below corresponding to the Connector Scheme chosen in Step 1, enter the letter corresponding to the correct connector orientation for each connector on End 2.

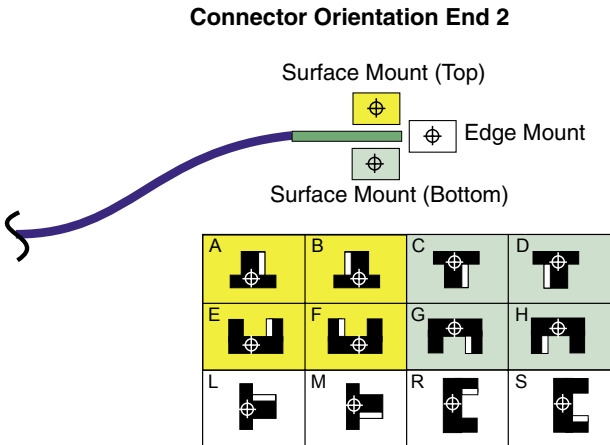
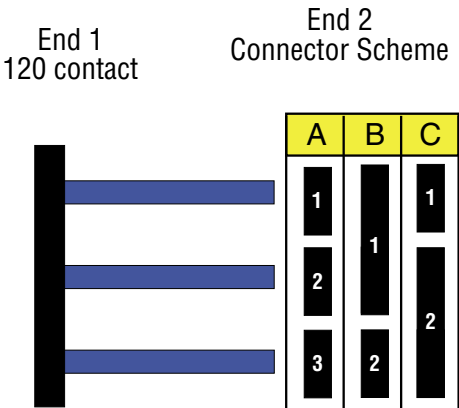

Note: All assemblies assume 1-1 mapping.

Orientation: Connector 1
 Connector 2
 Connector 3*

* This connector is not needed for every Connector Scheme.

Customer Approval: _____	Date: _____
Phone Number: _____	Company: _____
<p>Fax completed form to: 1-503-328-7087</p> <p>Attn: Tom Dersch 1-503-673-4593</p>	