

# MICTOR .635mm 152 contact Splitter Assembly

**POLICY**

Splitter assemblies are considered "custom," non-returnable items. Tyco Electronics does not take responsibility for any errors in configuration based on customer specifications entered on this form.

NOTE: Splitter assemblies are those with a single connector on End 1 and multiple connectors on End 2.

**Step 1: Using the table below, choose the End 2 Connector Scheme and enter letter from A to G:**

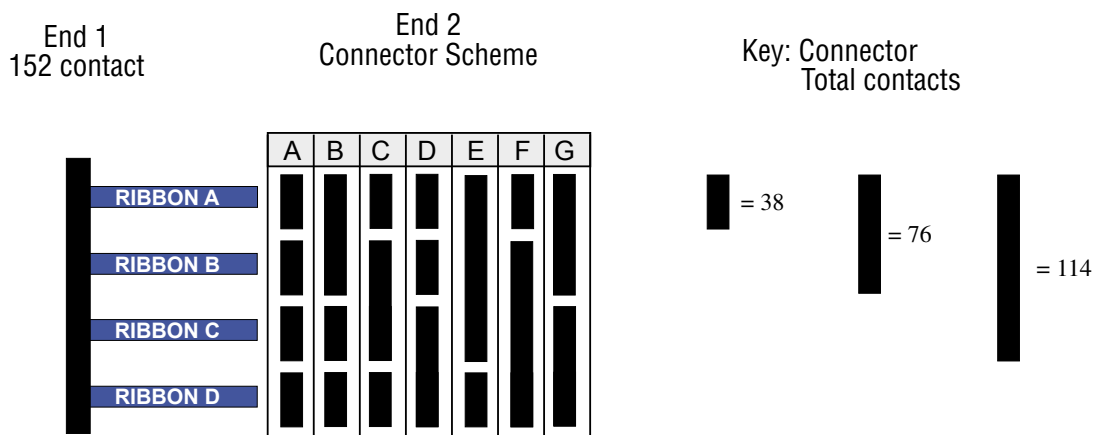

**Step 2: Step 2: Enter the length for each coax ribbon:**

Ribbon A  cm

Ribbon B  cm

Ribbon C  cm

Ribbon D  cm

NOTE: Each End 2 connector can have a different ribbon length. However, all ribbons going to a single connector must be the same. For example using connector scheme C

	<u>VALID</u>	<u>IN VALID</u>
Ribbon A	10cm	10cm
Ribbon B	20cm	20cm
Ribbon C	20cm	30cm
Ribbon D	40cm	40cm

NOTE: The overall length for each connector will be approximately 2-3 cm longer due to added length of conductors and housing.

# MICTOR .635mm 152 contact Splitter Assembly

Step 3: For End 1, enter the orientation of the 152 contact connector based on the table below:

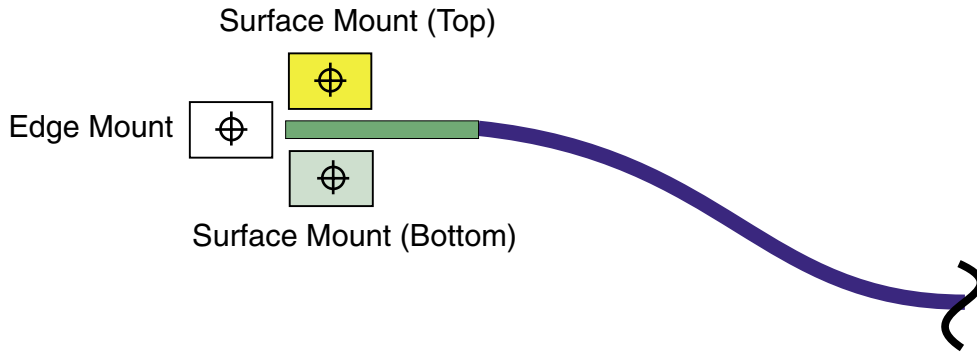

A	B	C	D
E	F	G	H
J	K	N	P

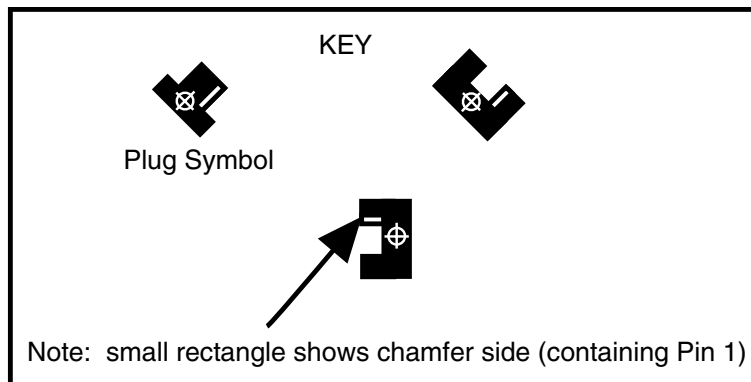

# MICTOR .635mm 152 contact Splitter Assembly

**Step 4:** Using a column in the table below corresponding to the Connector Scheme chosen in Step 1, enter the letter corresponding to the correct connector orientation for each connector on End 2.

End 1  
152 contact

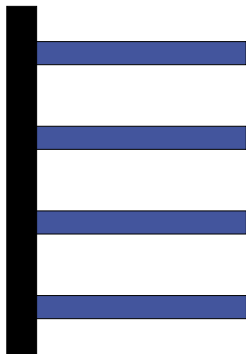

End 2  
Connector Scheme

A	B	C	D	E	F	G
1	1	1	1	1	1	1
2	2	2	2	1	2	1
3	3	3	3	2	3	2
4	4	4	4	3	4	3

Connector Orientation End 2

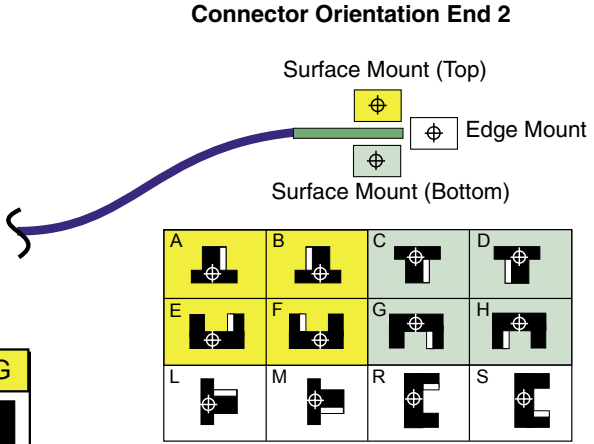

Note: All assemblies assume 1-1 mapping.

**Orientation:** Connector 1   
 Connector 2   
 Connector 3\*   
 Connector 4\*

\* This connector is not needed for every Connector Scheme.

Customer Approval: \_\_\_\_\_ Date: \_\_\_\_\_

Phone Number: \_\_\_\_\_ Company: \_\_\_\_\_

**Fax completed form to: 1-503-328-7087**  
**Attn: Tom Dersch 1-503-673-4593**